

WAFER LUG KNIFE GATE VALVE

The FPV Wafer Lug Knife Gate valve is designed as a space saving option for corrosive applications. The resilient seat is an elastomer sleeve, available in different materials. The sleeve supports and guides the gate and guarantees full tightness when closed. The valve can be used in either bi-directional or dead end service.

Product Specifications:

Size Range:	50 - 600 mm (2" - 24")
Valve Type:	Lug
Body Style:	Narrow, wafer
Gate Material:	17-4PH stainless steel, 316L stainless steel, 2205 duplex stainless steel, 2507 duplex, stainless steel, C276 HASTELLOY
Temperature Range:	-50°C - +80°C
Pressure Rating:	Up to 240 psi (16 bar)
Body Material:	Cast ductile iron & stainless steel, 2 coat epoxy painted
Seat Material:	Gum rubber, high-temp EPDM, neoprene, nitrile, chlorobutyl, urethane
Gland Packing:	PTFE impregnated synthetic fibre
Duty:	Corrosive applications
Hydro-Static Test	1.5 Times the rated pressure

Features:

- Replaceable reinforced elastomer seat.
- Face-to-face - MSS SP81.
- Valve body can be lined in rubber or urethane.
- Bubble tight shut off.
- External epoxy or powder coated.
- Easily adapted to fit most actuators.
- Low maintenance requirements.
- MSS-SP-81 face-to-face.
- Lock out and switch mountings.
- Live load packing gland.
- Full port and bi-directional.
- Lightweight material for easy handling.
- Minimised chest area & close tolerances preventing media from packing.
- Robust gate design reduces bending.
- Zero discharge to atmosphere.
- No pressure drop across valve.
- PTFE blade wiper.
- Once piece wafer body.



How the Valve Operates

Designed specifically for corrosive applications. The body and seat are designed to assure non-clogging shut-off/on suspended solids. The valve can be manufactured with replaceable sleeves.

Actuators

All types of actuators can be fitted; electric, gearbox, hydraulic, pneumatic and handwheel

Applications & Accessories

The valve is suited for mining and mineral processing, power generation, sand/gravel, chemical & soda ash, pulp & paper, environmental & effluent, dry feeds and powders.

- Limit switches
- PTFE blade coating
- Various blade materials
- Gate safety guards
- Deflector cone

Dimensions & Weights

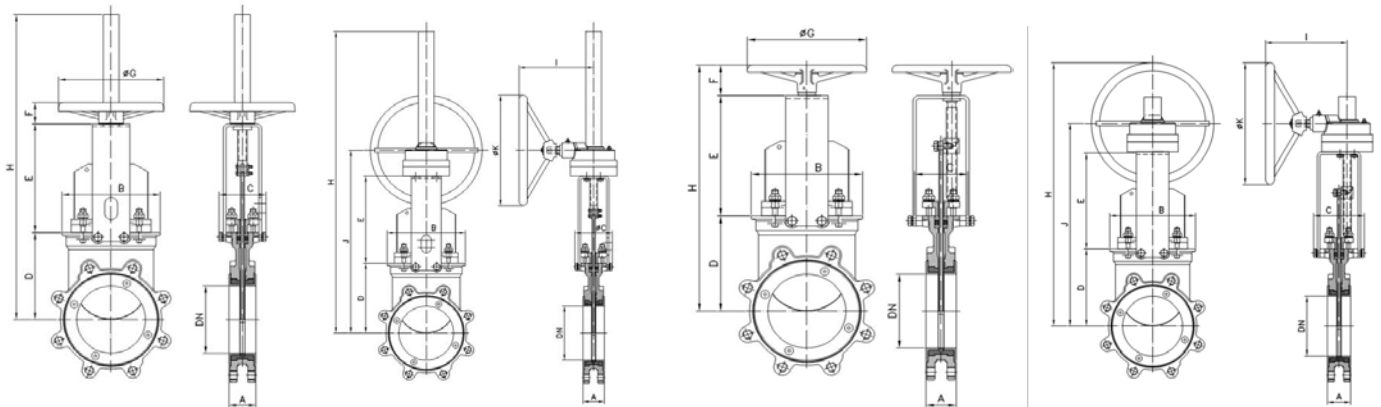

Valve Size	A	MSS-SP 81 - F/F	Lined F/F	C	D	E	F	G	H	I	J	MH kg	BG kg	AC kg
50	146	48	54	65	428	500	380	303	300	300	100	12	23	17
65	146	48	54	65	428	500	380	303	300	300	100	16	26	21
80	126	51	57	89	480	500	484	303	300	300	100	15	24	24
100	142	51	57	98	548	568	552	303	300	300	100	20	29	27
125	200	57	64	118	448	568	552	303	300	300	160	24	33	33
150	200	57	64	130	713	733	715	328	500	500	160	29	34	40
200	303	70	76	155	884	1004	874	328	500	500	200	62	65	83
250	322	70	76	161	1019	1039	1017	328	500	500	250	83	85	118
300	374	76	83	187	1234	1254	1185	328	600	600	300	102	101	145
350	444	76	83	222	1388	1400	1354	328	600	600	300	131	134	194
400	504	89	95	251	1508	1528	1474	328	600	600	400	182	182	263
450	568	89	95	284	1709	1739	1691	351	600	600	450	208	222	336
500	622	114	121	311	1871	1901	1853	351	600	600	450	268	282	396
600	712	114	121	355	2104	2134	2136	351	600	600	550	380	395	517

Dimensions and weights are for guidance only - detailed dimension drawings available on request. All dimensions are in millimetres, unless stated.